



RESEARCH ARTICLE

HARMONIC ANALYSIS OF CFL AND INCANDESCENT LAMP

*,¹GagandeepKaur and ²Dr. Ritula Thakur

¹ME Student (Electrical Engineering), NITTTR, Chandigarh, India

²Assistant Professor (Department of EE), NITTTR, Chandigarh, India

ARTICLE INFO

Article History:

Received 17th March, 2016
Received in revised form
20th April, 2016
Accepted 21st May, 2016
Published online 30th June, 2016

Key words:

Power quality, Harmonic distortion,
CFL lamp, Incandescent Lamp,
Fluke435, Fluke View.

ABSTRACT

Power quality has become a topic of concern due to extensive emphasis by power utility on the power system efficiency and customer awareness of power quality issues. This has occurred mainly due to the sensitivity of the modern equipment which are non-linear in nature and thus results in deregulation of the power distribution system. In addition, there are usually very high losses both to power utility and consumers due to poor power quality supplies which are below the set standards. Power quality parameters consist of voltage dips and swells, interruptions, harmonic distortions, voltage flickers, transients and frequency deviations. Among all harmonics are one of the major power quality concern. This paper mainly looks at effect of CFL lamps and Incandescent lamps on system in relation to harmonic distortions and low power factor. Power Quality Analyzer FLUKE 435 is used to carry out the harmonic analysis. The practical set-up used for this is available at NITTTR Chandigarh. The recorded harmonic data has established that the bulbs generate harmonic distortions above standards and leading power factor. Moreover combination of incandescent and CFL lamps was noted to improves the power quality.

Copyright©2016, GagandeepKaur and Dr. Ritula Thakur. This is an open access article distributed under the Creative Commons Attribution License, which permits unrestricted use, distribution, and reproduction in any medium, provided the original work is properly cited.

Citation: GagandeepKaur and Dr. Ritula Thakur, 2016. "Harmonic analysis of CFL and incandescent lamp", International Journal of Current Research, 8, (06), 33299-33303.

INTRODUCTION

Electrical loads which draw sinusoidal current from a sinusoidal voltage source are termed as linear loads. Such loads consist of resistive, inductive and capacitive passive elements. Whereas, non-linear loads draw non-sinusoidal current waveform, from a input sinusoidal voltage source. In order to show the undesirable effects and adversity of these non-sinusoidal signals, harmonic definition was introduced by Institute of Electrical and Electronics Engineers (IEEE) in 1981 which can be defined as the sum of the sinusoidal signals in different frequencies by Fourier series. According to IEEE Standard 519 (IEEE Std. 519-1981) reported in 1981, Harmonic is defined as "A sinusoidal component of a periodic wave which consists of a frequency that is an integer multiple of the fundamental frequency". The abundance usage of non-linear loads which contain power electronic devices, results in distorted current and voltage waveforms at the point of common coupling of industrial and domestic. Total Harmonic Distortion (THD) is the addition of each harmonic components of the voltage or current waveform compared with respect to

the fundamental component of the voltage or current wave. This is shown in Eqn given below

$$\text{Harmonic Factor (Voltage)} = \frac{\sqrt{\sum_{h=2}^{\infty} (V_h^2)}}{V_1} \tag{1}$$

$$\text{Harmonic Factor (Current)} = \frac{\sqrt{\sum_{h=2}^{\infty} (I_h^2)}}{I_1} \tag{2}$$

$$\text{Total Harmonic Distortion (THD)} = \frac{\sqrt{\sum_{h=2}^{50} (V_h^2)}}{V_1} \times 100\% \tag{3}$$

V_h: Magnitude of voltage harmonic component of order "h".

I_h: Magnitude of the current harmonic component of order "h".

Table I shows the voltage distortion values listed by IEEE 519-1992.

The TDD limit defines how much a load can allocate the utility resource in terms of harmonic current, and it is directly proportional with the size of the load with respect to the capacity of the utility at PCC. Therefore, the load can inject harmonic current to the end user at greater percentages as the rating of the load decreases with respect to the capacity of the system.

*Corresponding author: GagandeepKaur
ME Student (Electrical Engineering), NITTTR, Chandigarh, India.

Table 1. Voltage Distortion Limit

Bus Voltage at PCC	Independent Voltage Distortion (%)	Total Harmonic Distortion THD (%)
69 kV and below	3.0	5.0
69.00 kV through 161 Kv	1.5	2.5

Table 2. Current Distortion Limits for General Distribution Systems (120V through 69 kV)

Harmonic Order (Odd Harmonics), h	Max. Harmonic Current Distortion for h					TDD
	I_{sc}/I_L	$h < 11$	$11 \leq h < 17$	$17 \leq h < 23$	$23 \leq h < 35$	
Below 20	4.0	2	1.5	0.6	0.3	5.0
Between 20-50	7.0	3.5	2.5	1.0	0.5	8.0
Between 50-100	10.0	4.5	4.0	1.5	0.7	12.0
Between 100-1000	12.0	5.5	5.0	2.0	1.0	15.0

$$\text{Total Demand Distortion (TDD)} = \frac{\sqrt{\sum_{h=2}^{\infty} (I_h^2)}}{I_L} \times 100\% \quad (5)$$

I_L = Maximum demand Load Current

I_h = Magnitude of the harmonic current of order "h"

Sub-harmonics

"Sub-harmonics" is common definition given to inter-harmonics whose frequency is less than that of the fundamental that is $f > 0$ Hz and $f < f_1$.

Problems occur with Harmonics interface

Some of the problems associated with the harmonic interface are as follows:

- Increase losses both in the supply and inside supply transformer.
- Unwanted tripping of circuit breakers.
- Premature ageing of electrical insulation.
- Malfunions or failure of some electrical circuits.
- Possible cause of system resonance when power factor correction equipment is present on the system. This may impose high voltages currents on the system which can be dangerous.
- Premature failure of power factor correction / capacitor installations.

Effects of Harmonic In electrical power system

Harmonic distortion causes various problems towards the power system. Over voltage problems, instability of zero

voltage crossing firing circuits, overheating of neutral conductors and transformers and communication interferences are some of the current problems which found from harmonic distortion due to non-linear loads.

Sources of Harmonics

The power electronics equipments that produce harmonics in the power system are daily equipments use frequently by end users. Fundamental and harmonic power are shown in eq. (4) and eq. (5) as below

$$P_{\text{fundamental}} = V_{\text{fundamental}} \cdot I_{\text{fundamental}} \cdot \cos\theta_1 \quad (4)$$

$$P_{\text{harmonic}} = V_{\text{harmonic}} \cdot I_{\text{harmonic}} \cdot \cos\theta_{\text{harmonic}} \quad (5)$$

The harmonic currents flowing through the resistance of the circuit shows a power loss as $P_h = I_2^2 R_h$ harmonic. R_h can change with applied harmonics because of stray currents, skin effect, eddy currents, etc (Manzano et al., 2009).

Real time analysis

The real time analysis is carried out by using non-linear load comprising two CFL lamps of rating 23 W and 15 W connected parallel across the supply with the help of power quality analyzer Fluke 435.

Hardware Used

Power Quality Analyzer 435

POWER QUALITY ANALYZER FLUKE 435 versatile instrument for carrying out Vigilance checks, Surveys, Audits and Periodic Visits for checking at Industrial and Consumers end. The measurements can be done on Live loads. It is able to do almost all the analysis for single and three Phase supply and capable of analyzing standby Power consumption to the Maximum Demand of Factory.



Fig. 1. Power Quality Analyzer Fluke 435

Equipment Used During Testing

The experiment was done using 2 CFL bulbs of 23 Watt, 15 Watt in parallel and voltage rating of 240V, as shown in Fig. (3) and reference working equipment shown in Fig. (4). The equipment provides the instantaneous active power, reactive power, total power, power factor and harmonic distortions values. Incandescent bulb of 40 Watt, 100 Watt in parallel and

Incandescent bulb of 40 Watt, CFL bulb of 23 Watt in parallel and voltage rating of 240V were used as benchmark of the investigation continuous current waveform.

Experimental Setup

The main objective of this chapter is to identify the harmonics generated in a non-linear load in power system. The configuration of the experimental system block diagram is shown in Fig.2.

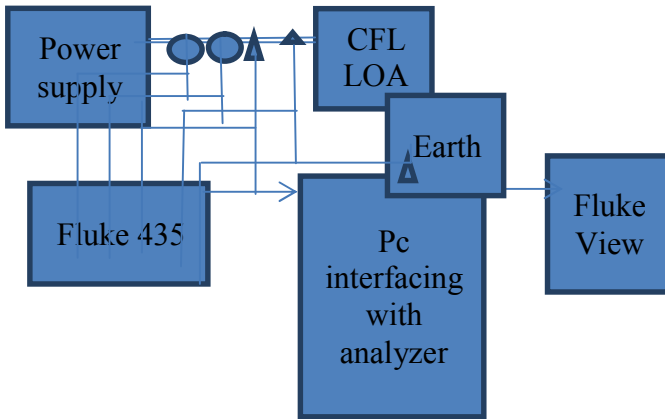

Fig. 2. Block Diagram

All experimental data has been collected in power electronics lab of EE Department, NITTTR Chandigarh. This lab has a 23W, 15W parallel connected CFL load and 23 W CFL and 40 W incandescent lamp load set-up.



Fig. 3. CFL bulbs in parallel

Experimental Tests on Compact Fluorescent

Compact Fluorescent Lamps are widespread in indoor lighting application. Compact fluorescent lamp ballasts are embedded and no external dimming system is provided. The physical set

up for compact fluorescent lamps measurements is shown in Fig. 4.



Fig.4. Physical setup in Power Electronics Lab NITTTR CHD

Harmonic Analysis Using Fluke 435

Menu displays a Meter screen with important numerical measuring value

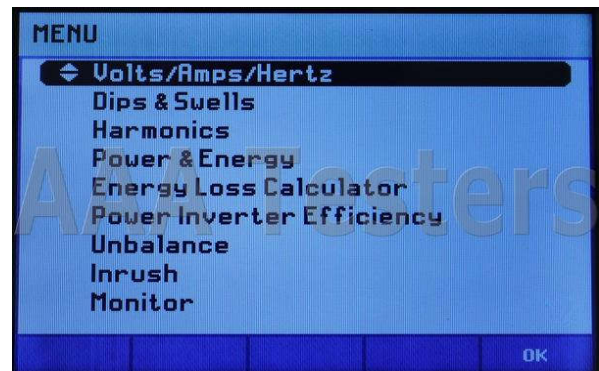

Fig. 5. Fluke Menu

Volts/Amps/Hertz			
		0:00:03	
	A		N
Vrms	234.75		173.07
Vpk	326.5		243.0
CF	1.39		1.40
Hz	50.006		
	A		N
mA rms	0.7		0.4
mA pk	1.5		0.5
CF	OL		OL
24/03/16 17:02:22 230V 50Hz 1Ø EN50160			
VOLTAJE		TREND	HOLD RUN

Fig. 6. Volts/Amps/Hertz

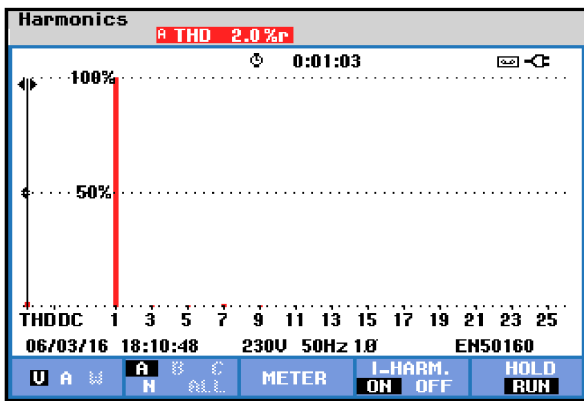

Fig. 7. Voltage Harmonic Distortion

Experimental Tests on Compact Fluorescent Lamp in Parallel with Incandescent Lamp



Fig.11. Incandescent bulb in parallel with CFL

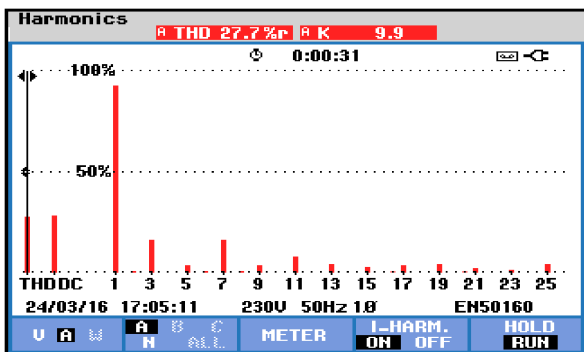

Fig. 8. Current Harmonic Distortion

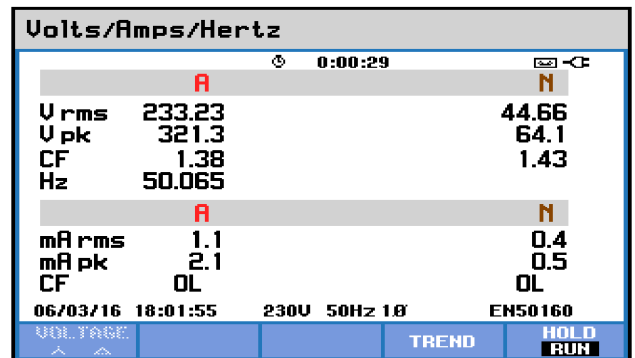

Fig. 12. Volts/Amps/Hertz

HARMONICS TABLE		
Amp	A	N
THD%r	27.2	90.5
H3%r	15.2	0.4
H5%r	3.4	0.2
H7%r	15.8	0.2
H9%r	3.9	0.2
H11%r	7.5	0.3
H13%r	4.6	0.4
H15%r	3.3	0.3

Fig. 9. Harmonic Table

HARMONICS TABLE		
Amp	A	N
THD%r	3.8	92.0
H3%r	1.4	0.3
H5%r	1.0	0.1
H7%r	1.0	0.3
H9%r	0.6	0.2
H11%r	0.3	0.3
H13%r	0.2	0.2
H15%r	0.2	0.3

Fig. 13. Harmonic Table

Power & Energy		
FUND	A	Total
W	0.14	0.14
VA	0.15	0.15
VAR	0.04	0.04
PF	---	---
Cosφ	---	---
mA rms	0.7	
<hr/>		
U rms	234.85	

Fig. 10. Power and Energy

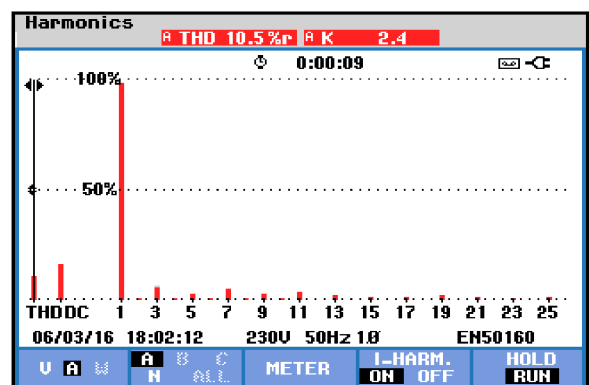

Fig.14. CFL bulbs in parallel

HARMONICS TABLE		
0:00:02		
Volt	A	N
THD%	1.9	1.5
H3%	0.6	1.0
H5%	0.8	0.7
H7%	1.4	0.7
Amp	A	N
H3%	5.4	0.1
H5%	2.5	0.1
H7%	3.8	0.2
06/03/16 18:07:42 230V 50Hz 1Ø EN50160		
U A U HARMONIC GRAPH TREND HOLD RUN		

Fig. 15. Harmonic Table

Power & Energy		
FUND 0:00:06		
	A	Total
W	- 0.25	- 0.25
VA	0.26	0.26
VAR	0.04	0.04
PF	---	---
cos ϕ	---	---
mA rms	1.1	
V rms	233.16	
06/03/16 18:02:27 230V 50Hz 1Ø EN50160		
VOLTAGE ENERGY TREND HOLD RUN		

Fig. 16. Power and Energy

Data Analysis

From the data recorded, it is analyzed that CFL lamps generate high reactive power hence low leading power factor and odd harmonic distortions as shown in Fig.9. This is mainly because of the Switch Mode Power Supplies placed in their electronic circuit. They generate higher odd harmonic current distortions due to their innate drawing of non-periodic current. The current Total Harmonic Distortion (THDi) is high for CFL bulbs (28 %) as shown in fig.8 as compare incandescent bulbs experiment (10.8%) due to innate non linearity of electronic components. In additional, CFL bulbs consume less active power (75% less than counterpart bulbs) as they consume discontinuous current of each half cycle. Incandescent bulbs draw more active power thus the system carries high current fig. However, they have merely a unity power factor and low total harmonic distortions (4%), hence cause less danger on

power quality. Moreover it is found that in using incandescent bulbs and CFL in parallel improve the power quality considerably.

Conclusion

No doubt the CFL bulbs are much better than incandescent bulbs in terms of power saving but the total current drawn by the CFL which constitute more than 50% reactive and harmonic currents which are directly causing harm to the power system if such equipments used in bulk. Thus proper mitigation techniques such as Filters, Custom Devices, FACTS etc. should be taken in to considerations to reduce the THD below IEEE standards. Moreover it has been found that on combining CFL and incandescent bulbs power quality is improved supplied at the point of common coupling (PCC) as THD is found to be 10.6 % which is one third of the THD in case two CFL loads in parallel

REFERENCES

- Dolara, A.; Faranda, R.; Guzzetti, S.; Leva, S. 2010. Power Quality in Public Lighting Systems. In Proceedings of the 14th International Conference on Harmonics and Quality of Power (ICHQP 2010), Bergamo, Italy, 26–29 September.
- Falvo, M.C.; Grasselli, U.; Lamedica, R.; Prudenzi, 2010. A. Harmonics Monitoring Survey on Office LV Appliances. In Proceedings of the 14th International Conference on Harmonics and Quality of Power (ICHQP 2010), Bergamo, Italy, 26–29 September.
- IEEE Std. 519-1981, “Guide for Harmonic Control and Reactive Power Compensation of Static Power Converters”.
- IEEE Std. 519-1992, “IEEE Recommended Practices and Requirements for Harmonic Control in Electrical Power Systems”.
- Manzano, E.R.; Carlorosi, M.; Tapia Garzon, M. 2009. Performance and Measurement of Power Quality Due to Harmonics from Street Lighting Networks. In Proceedings of the Conference on Renewable Energies and Power Quality (ICREPQ'09), Valencia, Spain, 15–17 April.
- Monte, K.R.; Sen, P.K. 2010. Compact Fluorescent Lamps and Their Effect on Power Quality and Application Guidelines. In Proceedings of the Industry Applications Society Annual Meeting (IAS), Houston, TX, USA, 3–7 October.
- RigoMariani, R.; Rayudu, R.K.; Witherden, M.S.; Lai, E.M. 2010. Power Quality Indices of Compact Fluorescent Lamps for Residential Use—A New Zealand Study. In Proceedings of the IEEE TENCON 2010, Fukuoka, Japan, 21–24 November, pp. 647–652.
