



RESEARCH ARTICLE

WASTE MANAGEMENT OF DAMAGED CARS/ AUTO VEHICLE WHOSE DUMPED IN THE  
WAREHOUSES (OPEN ENVIRONMENT)

\***Mohammad TariqueJamali**

Lecturer in Industrial Engineering, Department of Industrial Engineering, King Khalid University,  
Abha, Kingdom Of Saudi Arabia

ARTICLE INFO

**Article History:**

Received 19<sup>th</sup> February, 2017  
Received in revised form  
21<sup>st</sup> March, 2017  
Accepted 24<sup>th</sup> April, 2017  
Published online 31<sup>st</sup> May, 2017

ABSTRACT

Now a day, the world face a huge problem to dumped the old cars/ auto vehicle when it is not working or damaged. This study shows that how we managed the old cars/ auto vehicle to useful for human beings and also clean the ware houses for another storage work. We do the dis-assemblies of these cars in a predetermine assembly line. and then find out which component is useful and which component are useful after heat treatment or small manufacturing works and which components are totally damaged or not utilized again (we dumped it properly).

**Key words:**

Assembly Line/ Production Line,  
Disassembly of Auto- Vehicle,  
Waste Management,  
Alloys,  
Car Components.

Copyright©2017, Mohammad TariqueJamali. This is an open access article distributed under the Creative Commons Attribution License, which permits unrestricted use, distribution, and reproduction in any medium, provided the original work is properly cited.

**Citation: Mohammad TariqueJamali, 2017.** "Waste management of damaged cars/ auto vehicle whose dumped in the warehouses (open Environment).", *International Journal of Current Research*, 9, (05), 51053-51055.

INTRODUCTION

In this study, we make an assembly line to dis-assemble the all the component of old car/ auto vehicle in a sequence. First we dis-assemble the component like tires, wheel rim, upper body of car like doors, wind screen, roofs etc. chassis( axle "live /rare", shock absorber mufflers, fuel tanks etc. ), Steering assembly,, car engine, engine fan, piston, battery, radiator, clutches, fuel injector, transmission, air filters, catalytic converters, alternators, AC compressor, spark plug, brakes, pressure gauge etc. after disassembly the component of car we store in the as an out- put / storage. Then we examine the component is good / semi damaged or damaged. If the component is good than put in one store reuse in for another car/ auto vehicle. For semi damaged or damaged components processing done by heat treatment and machining. If the component are damaged and material is iron/ tin sheet then melted it make new iron/tin sheet. And reuse it for making another product.

**Theory:** Here we take a batch of 100 damaged car/ auto vehicle.

**Corresponding author: Mohammad Tarique Jamali,**

Lecturer in industrial Engineering, Department of Industrial Engineering, King Khalid University, Abha, Kingdom Of Saudi Arabia.

Disassemble by an assembly/ production line as that manner the coding are given for utilizing the robotics arm. We take one by one car as a input then make a coding. These are

**For wheels of car**

D1 means disassembly of car wheels. They have nearly two major components these are D11- Disassemble tire, D12- Disassemble rim For storage we tire and rim we say that SD11 for disassemble tire, SD12 for disassemble rim Examine this if good use it another car if damages recycle the rubber tire and recast the Al alloy rim For car Body

D2 – disassemble the car body

D21- disassemble the car wind screen, doors, D22- disassemble the car roofs

SD21- storage for door sheets and fibers wind screen

SD22- Storage for roof ( tin sheet or Al Alloy sheet)

Examine this if good use it another car if fiber glass is damaged then dumped it. For Al Alloy or tin sheet we recast it or give small heat treatment and other manufacturing process.

**The Example of assembly line of a disassembled car are as follows**

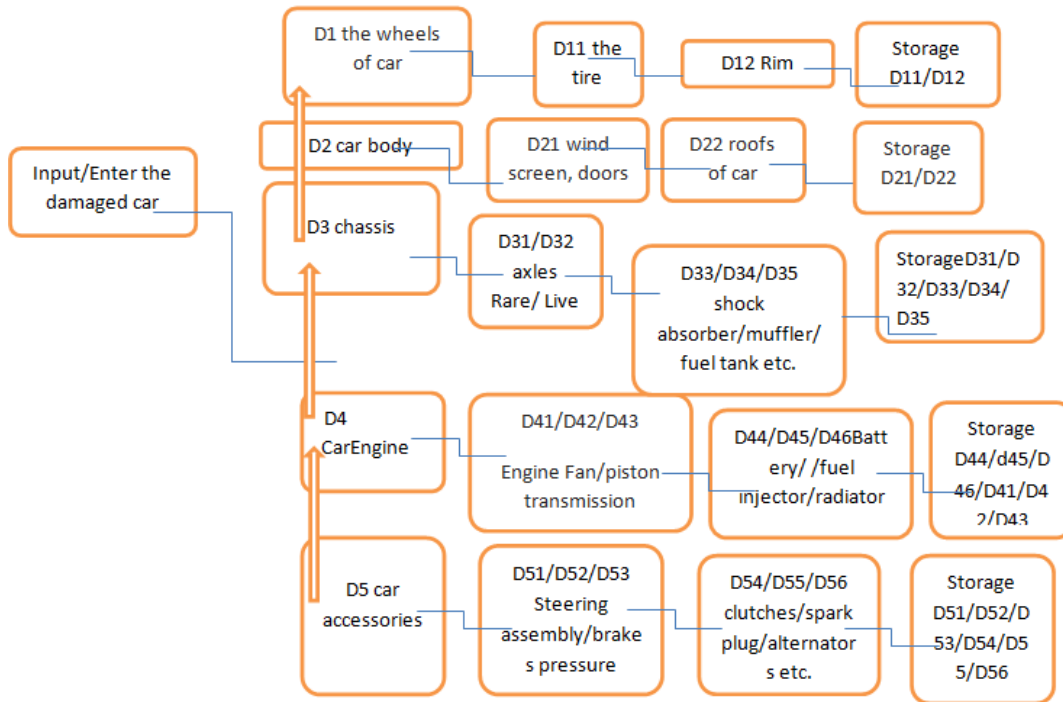

**Figure 1. Of an assembly line of an Car/ auto vehicle disassembly**

**For chassis**

D3- disassemble the chassis

D31- disassemble the rare axle, D32- disassemble the live axle

D33- disassemble the shock absorber, D34- disassemble the muffler

D35- disassemble the Fuel tank

**Similarly for storage**

SD31- storage of the rare axle,

SD32- storage of the live axle

SD33- storage of the shock absorber, SD34- storage of the muffler

SD35- storage of the Fuel tank

Similarly if the component is good reuse another car and if damaged recast or recycle it.

**For Car Engine**

D4 – disassemble the car Engine

D41- disassemble the Engine Fan,

D42- disassemble the piston

D43- disassemble the transmission assembly, D44- disassemble the Battery

D45- disassemble the Fuel injector, D46-disassemble the radiator

**Similarly for storage**

SD31- storage of Engine fan, SD32- storage of the piston

SD33- storage of the transmission assembly, SD34- storage of the radiator

SD35- storage of the Fuel Injector

Similarly if the component is good reuse another car and if damaged recast or recycle it.

**Similarly For car Accessories**

D5 – disassemble car Accessories

D51,D52,D53,D54,D55,D56 for disassemble the steering assembly, brakes, pressure gauge, clutches, spark plug, alternator respectively.

**And for storage**

SD51,SD52,SD53,SD54,SD55,SD56 for the storage of steering assembly, brakes, pressure gauge, clutches, spark plug, alternator respectively.

Similarly if the component is good reuse another car and if damaged recast or recycle it. We draw a propose disassembly (Assembly/ Production line) here. for a sequence given above in coding for robotics arm

**RESULTS**

After Examine the all component in the storage we see that

- A lot of Al alloy, tin sheets, and iron is found from the damaged components of the auto vehicle/cars. they are re-casted or reprocessing for making new products.

- for good components We use for another car for alteration( maintenance work)
- we found a lot of rubber from tires we recycle it and make new product from rubber
- we clean the ware houses( open environment) where the damaged car are store it land is utilize for another work.

### **Conclusion**

#### **For using this waste management system for damaged auto vehicle/ cars.**

- we clean a lot of area occupied by these cars for several years stay in warehouses
- Found the many useful component for alter the another cars.
- Also found the useful material of Al alloy, tin sheet, Iron by recasting ( heat treatment or melting) it.

- Future scope-
- Scientist also calculate the dis-assembly rate by using the production rate philosophy and see the effectiveness of this on dis-assembly rate.
- Cost analyzer also calculate the it is benefited by the organization or not
- Environmentalist see the how much pollution occurs from recasting the alloys, rubbers or reduce pollution when disassemble the component of auto vehicle/ cars

### **REFERENCES**

For car components “[www.google.com](http://www.google.com)”

\*\*\*\*\*