



ISSN: 0975-833X

Available online at <http://www.journalcra.com>

International Journal of Current Research
Vol. 11, Issue, 06, pp.4821-4829, June, 2019

DOI: <https://doi.org/10.24941/ijcr.35744.06.2019>

INTERNATIONAL JOURNAL
OF CURRENT RESEARCH

RESEARCH ARTICLE

EVALUATION OF MECHANICAL, PHYSICAL AND THERMAL PROPERTIES OF PARTICLEBOARD FROM TEAK (*TECTONA GRANDIS*) SAWDUST WITH THE TANNIC POWDER OF AFRICAN LOCUST BEAN POD (*PARKIA BIGLOBOSA*)

1,2,4Soviwadan DROVOU, 1,*Komlan A. KASSEGNE, 1,2Komi KADJA, 5Demagna KOFFI, 6Yao KOUTSAWA and 2,3Komla SANDA

¹National Advanced School of Engineers, University of Lomé, (ENSI – UL) Lomé, Togo

²Unit of Research on Agro-resources and Environmental Health, University of Lomé, (URASE – UL) Lomé, Togo

³Advanced School of Agronomy, University of Lomé, (ESA – UL) Lomé, Togo

⁴laboratory for the Study and Research on Wood Material, University of Lorraine (LERMAB – UL)Épinal, France

⁵Ecole d'Ingénierie, Université du Québec à Trois-Rivières, CP 500, Trois-Rivières, Québec, G9A 5H7, Canada

⁶Materials Research and Technology Department, Luxembourg Institute of Science and Technology, 5, rue Bommel, Z.A.E. Robert Steichen, L-4940 Hautcharage

ARTICLE INFO

Article History:

Received 17th March, 2019

Received in revised form

14th April, 2019

Accepted 20th May, 2019

Published online 30th June, 2019

Key Words:

Particleboard; Sawdust of Teak,
Tannic Powder of Pod Locust Bean;
Mechanical, Thermal and Physic Properties.

ABSTRACT

The goal of this work is to develop, carpentry residues which are sawdust of teak, and agricultural, the African locust bean pod (*Parkia biglobosa*), for the manufacture of particleboards. So we research a palliative to environmental problems caused by sawdust and the use of conventional binders. Teak sawdust particleboards were manufactured by varying the content of tannin powder of African locust bean pod. The mechanical, thermal and physical properties of these panels were determined using three-point bending test, tensile test, internal bond, swelling in water and thermal conductivity measurement. The bending test was used to determine the modulus of elasticity (MOE) and the modulus of rupture (MOR). The tensile test leads to the determination of the Young modulus (E) and the modulus of rupture (MOT). The immersion in water allows determining the rate of thickness swelling and water absorption after two and twenty-four hours. The thermal property evaluated is the thermal conductivity coefficient. This shows that the tannic powders can validly replace the conventional binders in the manufacture of particle board.

*Corresponding author:

Soviwadan DROVOU

Copyright © 2019, Soviwadan DROVOU et al. This is an open access article distributed under the Creative Commons Attribution License, which permits unrestricted use, distribution, and reproduction in any medium, provided the original work is properly cited.

Citation: Soviwadan DROVOU, Komlan A. KASSEGNE, Komi KADJA, Demagna KOFFI, Yao KOUTSAWA and Komla SANDA, 2018. "Evaluation of mechanical, physical and thermal properties of particleboard from teak (*tectona grandis*) sawdust with the tannic powder of african locust bean pod (*parkia biglobosa*)", *International Journal of Current Research*, 11, (06), 4821-4829.

INTRODUCTION

The market for fiberboard and particle-based wood residues and agricultural products is marked by strong growth in the last decade (EPF, 2006). Also the importation of fiberboard, particleboard, tackles, laminate and veneer sheets have increased exponentially and the demand continues to grow (DSCN TOGO., 2015). In developing particleboard, binders such as urea formaldehyde, phenol formaldehyde, isocyanate melamine are used (Yemele, 2008). Urea formaldehyde binders with moderate costs are much used in the particleboard industry for indoor use. The panels based on this binder don't resist in water and emit formaldehyde dangerous for humans and the environment (Yemele, 2008). Indeed, formaldehyde is now classified as a carcinogen by the International Agency for

Research on Cancer (IARC, 1995). As for phenols formaldehyde, high cost, they emit the phenol in the environment with has high toxicity power (Huang, et al., 1992). For this reason, today, their usedis avoided. Polyisocyanate adhesives are also expensive and the free isocyanate group remains dangerous to public health (Yemele, 2008). These problems of conventional binders have led to search alternative solutions. One solution is to reduce formaldehyde levels, but this reduction has a negative effect on the mechanical properties of particleboard and also does not eliminate formaldehyde emission (Beyer, 1997). The second option is the chemical modification of resins based on formaldehyde: it does not also prevent the emission of formaldehyde (Lavischi, et al., 2001). The third option is to avoid formaldehyde emission by using plating.

But this solution is only temporary because the life of the barrier is limited (Orica, 1999). The inefficiency of the solutions presented above led to research for other less polluting alternatives, toxic less to replace conventional binders. Thus, biological glues (animal and plant) have nowadays a renewed interest. These biological glues are gelatins, white of egg, casein, derived of fats, polysaccharides, vegetable proteins, lignin and tannins. In his work, Nenonene explored the vegetal tannin such as African locust bean pod (Nenonene, 2009). His research gives us one base to solve the great problem: the choice of binder without emission of formaldehyde, and achieve good mechanical panels that are resistant to insects and microbial agents (Drovou *et al.*, 2015). The fields of the central and north region of Togo, have a lot of a tannic waste: the African locust bean pod. In this study, we present the results of the testing of an original method to make panels using carpentry residues: teak sawdust, with unconventional binder, the powder of African locust husk (*Parkia Biglobosa*).

MATERIAL AND METHODS

The raw material

Sawdust of teak (*Tectona Grandis*): They are collected from carpentry, in Lomé, Togo. Teak (*Tectona grandis*) is one of the world's hardwood timbers, rightly famous for its mellow color, fine grain and durability. It occurs naturally only in India, Myanmar, the Lao People's Democratic Republic and Thailand (White, 1991), and it is naturalized in Java, Indonesia, where it was probably introduced some 400 to 600 years ago. In addition, it has been established throughout tropical Asia, as well as in tropical Africa (including Côte d'Ivoire, Nigeria, Sierra Leone, the United Republic of Tanzania and Togo) and Latin America and the Caribbean (Costa Rica, Colombia, Ecuador, El Salvador, Panama, Trinidad and Tobago and Venezuela). Teak has also been introduced in some islands in the Pacific region (Papua New Guinea, Fiji and the Solomon Islands) and in northern Australia at trial levels. Although teak is the name used for international trade, there are many local names used as well: sagun, tegu, tegina, thekku (India); lyiu, kyun (Burma); mai sak (Thailand); jati (Indonesia); fati (Malaysia); teca (Latin America); and teck (France) (Chudnoff, 1984); (Keiding, 1985).

In 1856, realizing the commercial and strategic importance of the forests on the Indian subcontinent, the British brought several German botanists and foresters to India for the purpose of developing sustainable forest management plans. Notable among those individuals was Dr. Deitrich Brandis who developed a silvicultural management plan for the natural forests of India, called the "Brandis Selection System", which involves timber removal every 30 years and a final harvest between ages 120 and 150 years (Kahr, *et al.*, 2004). The final harvest age has now been reduced to 30 to 60 years with coppicing and replanting used to regenerate the teak forests (Pandey, *et al.*, 2001). Burma (now Myanmar) began planting teak using the taungya system in 1856 and, by 1961, had a total of 47,000 hectares planted. Large scale planting was again initiated in the 1980's and there were 307,000 ha of teak planted by 2002 (Swe Swe Aye, 2003). On the Island of Java there have been more than one million hectares planted with teak since the middle of the Nineteenth Century (White, 1991). Teak was first planted in Nigeria in 1902, in Togoland (now Ghana) in 1905 and in the Ivory Coast (Côte d'Ivoire) in 1929

(Horne, 1966; Kadambi, 1972). Initial plantings in West Africa were made using seed obtained from India, but it was soon learned that Burmese seed sources were superior in form and growth in the environments of West Africa. Teak was first introduced into the Americas at Trinidad in 1913 using Burmese seed sources (Streets, 1962). Teak was first planted in Central America in 1926 at the Summit Botanical Garden in the former Channel Zone of the Panama Canal (De Camino *et al.*, 2002). The following year other plantings were initiated in other Central American countries including Honduras, Panama and Costa Rica. Since then it has been planted in nearly all tropical American countries. By 2000, the total area in teak plantations worldwide was 5.7 million hectares, or 3% of 2 all forest tree plantations (FAO, 2001). By far, the largest extension of teak plantation is in Asia (Table 1).

Table 1. Area in teak plantations by geographic region in 2000

Region	Teak (ha)
Asia	5,409,131
Africa	206,550
Central America	76,000
South America	17,500
Oceania	7,022
World total	5,716,203

The pod of African locust bean (*parkia Biglobosa*)

Parkia biglobosa is one of spontaneous plants in sub-Saharan Africa and the most protected by local people because of its many uses (food, feed, fertilizer and soil restoration, crop protection and animal health, energy resources, habitat, tannery, toxic in water, etc. (Berhaut 1975; Tchiégang-Megueni *et al.*, 2001; Mapongm and Sem *et al.*, 2004). It is the wood used in the manufacture of paper pulp Fermented seeds. It is also used to produce a condiment marketed on all local and regional markets and known under various names: Iru Nigeria Dawa Dawa Cameroon, Sumboula Mali, Tsodi or Tsodou in Togo (Berhaut 1975; Ndirretal., 2000). The pods are used to buff colored fabrics (Berhaut, 1975) and for tanning hides, in Togo, to treat the floors and walls of mud houses against humidity. The bark of the stem is used for preparing several traditional medicines (Séné *et al.*, 1999), and as toxic in water (Fafioye *et al.*, 2004). The pods can be used as fertilizer, fish poison or as plaster for the wall.

The laboratory material

- a hot air oven at maximum temperature of 200°C Memment mark,
- a brand hammer mill RETSCH, Type SK 1000, with a 2 mm sieve to transform the pod of African locust in powder,
- manual hydraulic thermal press CARVER mark, maximum pressure of eleven (11) bars, with a mold of 300 mm x 300 mm, facilitating the pressing of particleboard,
- a brand mixer Laurent Perrier, for mixing the particles and the binder,
- a brand mechanical test bench INSTRON type 4467 equipped with various accessories for the various tests namely, tensile, compression, bending three points and four points, internal bound and Brinell hardness.

Sample preparation: Sawdust of teak from carpentry, are steamed at 70°C for 72 hours.

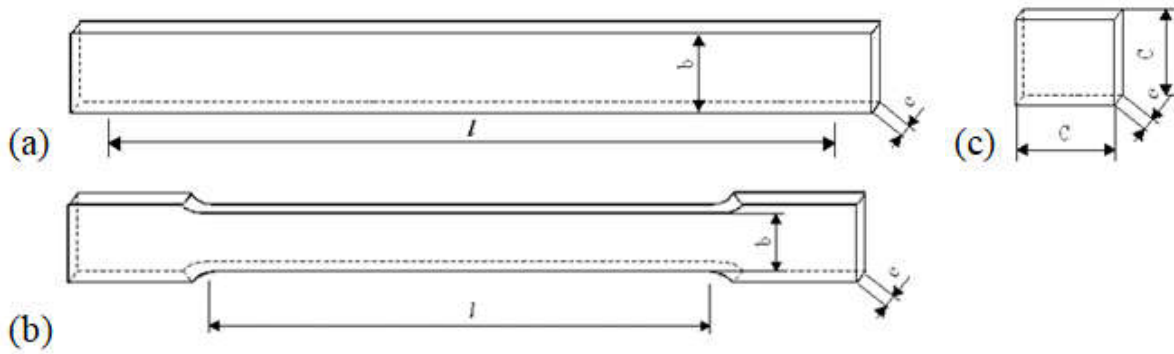

Figure 1. Samples for test of: (a), bending; (b), tension; (c), internal bound and the thickness swelling

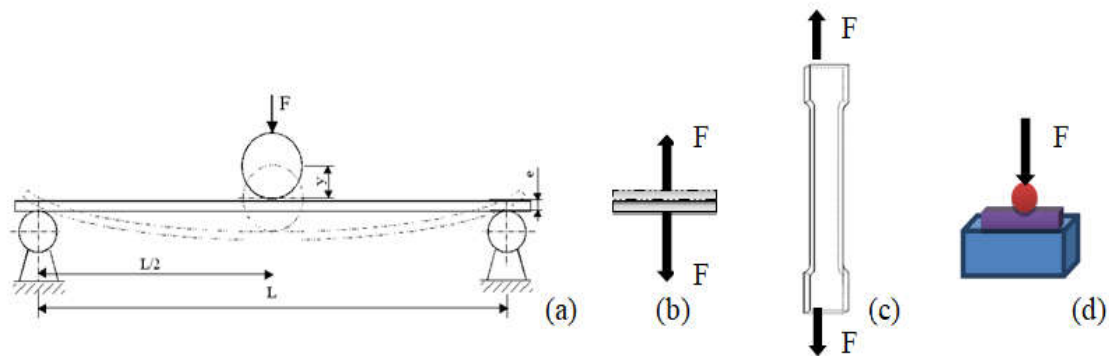

Figure 2. Diagram of the test principle of: (a) three-point bending, (b) internal bound, (c) tensile (d) Brinell hardness

Table 2. Characteristics required for particle board according to the US standard ANSIA 208.1.

class	MOR (MPa)	MOE (MPa)	IB (MPa)	Hardness (N)	Maximal tension (%)
H-1	16,5	2400	0,90	2225	NS
H-2	20,5	2400	0,90	4450	NS
H-3	23,5	2750	1,00	6675	NS
M-1	11,0	1725	0,40	2225	0,35
M-S	12,5	1900	0,40	2225	0,35
M-2	14,5	2225	0,45	2225	0,35
M-3	16,5	2750	0,55	2225	0,35
LD-2	5,0	1025	0,15	NS	0,35
LD-1	3,0	550	0,10	NS	0,35

MOR: breaking stress; MOE: modulus of elasticity; NS: not specified;
 H: high density panels: density > 800 kg /m³ (H-1, 2, 3 Industrial use);
 M: medium density panels: density is from 640 to 800 kg /m³ (M-1, MS Commercial Use, M-2, M-3 Industrial use);
 LD: low-density panels: density < 640 kg /m³ (LD Used for door soul).

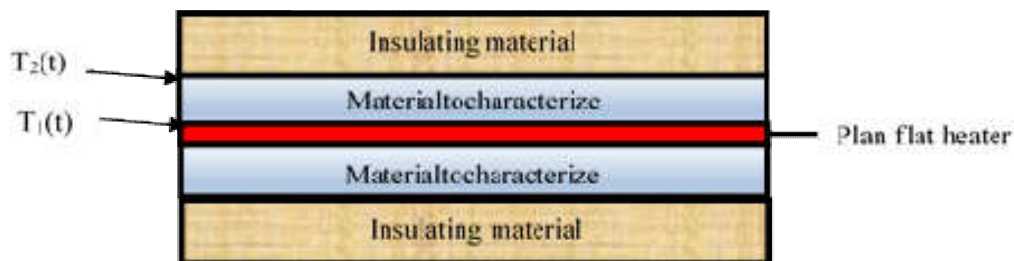

Figure 3. Installation diagram of the hot-plan approach with two samples

Pod of African locust bean steamed, is cut and ground with a hammer mill fitted with a 2 mm sieve then sieved with a sieve of 0.125 mm to separate the fibers of the pod. The latter is mixed with the sawdust to different rate of 5; 6.5; 7; 7.5; 8; 10; 12.5 and 15%. The particles, African locust bean husk powder and water were mixed for ten minutes and pressed at a temperature of 160°C and at a pressure of 11 bars for 15 minutes.

The panels were made in the Laboratory of Research on Agriculture resources and Environment health (LARASE) of University of Lomé – Togo. These particleboards are cut into different specimens at the Laboratory for Study and Research on Wood Material (LERMAB) at the National advanced School of Technology and Wood Industries (ENSTIB) of the University of Lorraine France. The samples have the dimensions of: 150 mm by 100 mm for the bending test; 50

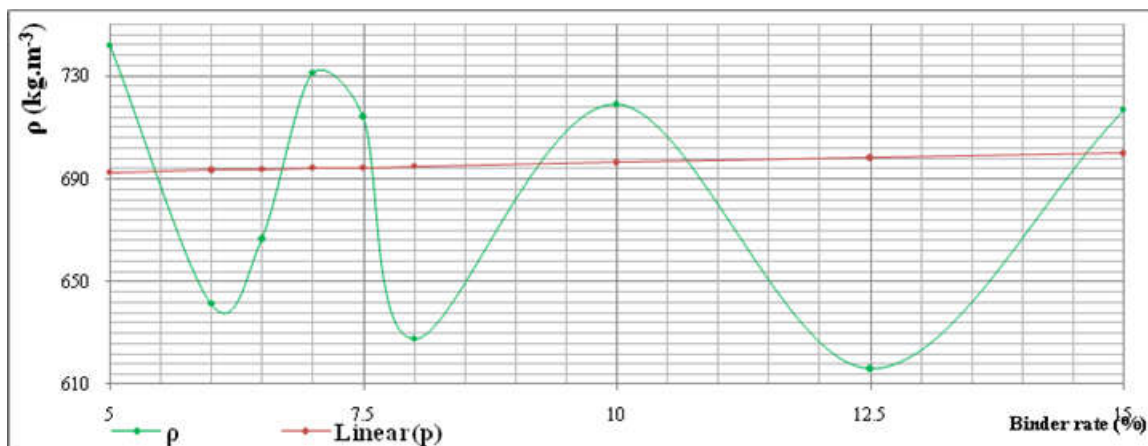

Figure 4. Variation of the density (ρ) according to the binder rate

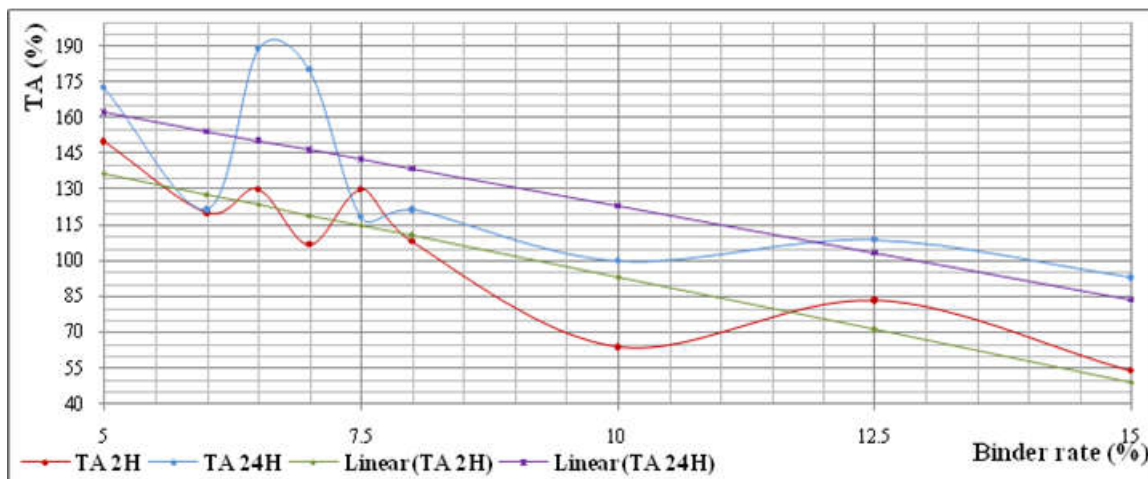
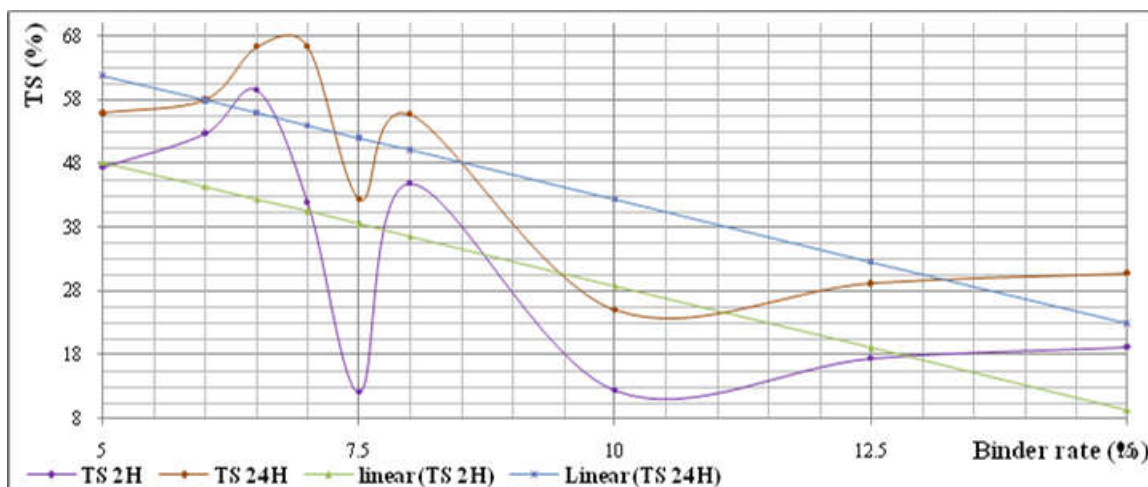

Figure 5. Variation of the (a): thickness swelling, (b): water absorption, rate after 2 and 24 hours according to the rate of binder

mm x 50 mm for internal bound; 30 mm by 150 mm for tensile test. The figures 1 show the samples for different tests.

Mechanical properties determination: The mechanical tests: tree points bending, tensile, internal bound and Brinell hardness are performed according to (EN 312-2, 2004). Their principle is shown on Figure 2. From these tests, the mechanical properties such as modulus of elasticity (MOE), modulus of rupture (MOR) for the bending, the Young's modulus (E), and modulus of rupture (MOT) for the tensile and the internal bound (IB)are over calculated.

Indeed, assuming a homogeneous and isotropic material, the bending elastic modulus is given by the following expression:

$$MOE = \frac{Fl^3}{4be^3y} \tag{1}$$

NBN EN 310: 1999 and EN 310 NF B51 - 124, 1993 (EN 310 NF B51 - 124, 1993) particleboard in terms of advocating a modulus of elasticity which strength F is taken between 10 and 40% of the breaking force. So finally:

Table 3. Physical properties of teak sawdust particle boards

Binder rate (%)	ρ (kg/m ³)	TS (%)		TA (%)	
		2H	24 H	2H	24 H
5	741.9	47.5	55.83	150	172.7
6	641.1	52.78	58.05	120	121.4
6,5	666.7	59.44	66.25	130	188.9
7	731.1	41.94	66.25	107	180
7,5	714.3	12.22	42.37	130	118.2
8	627.5	44.84	55.69	108	121.4
10	719.14	12.5	25	63.63	100
12,5	615.95	17.5	29.17	83.33	109
15	716.87	19.17	30.83	53.85	92.86

ρ : density;TA: Water absorption rate TS: Thickness swelling rate.

Table 4. Mechanical properties of teak sawdust particleboards

Binder rate (%)	E (MPa)	MOT (MPa)	MOE (MPa)	MOR (MPa)	IB (MPa)	HB (MPa)
5,0	6620	11.82	4320	2.87	0.46	17.897
6,0	4520	11.18	4900	2.33	0.47	17.881
6,5	4270	10.56	5600	2.23	0.50	17.866
7,0	4430	10.02	6600	2.25	0.52	18.123
7,5	5830	9.55	7300	5.26	0.56	18.180
8,0	4092	9.06	7800	2.21	0.59	23.386
10,0	5830	8.57	8900	4.42	0.57	28.591
12,5	5790	14.14	8800	6.78	0.63	35.774
15,0	4970	10.20	10000	3.90	0.61	33.513

MOR: modulus of rupture; MOE: modulus of elasticity;IB: Internal bound, E: elasticity limit; MOT: Tensile modulus of rupture; HB: Brinell hardness

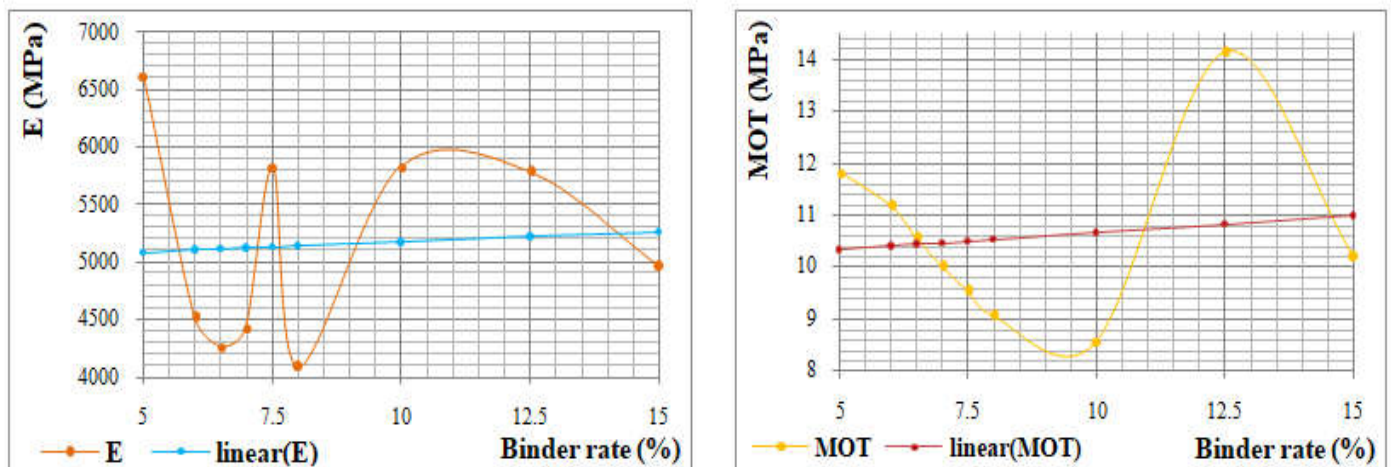

Figure 6. Variation of the tensile modulus of Young (E) and rupture (MOT) according to the binder rate

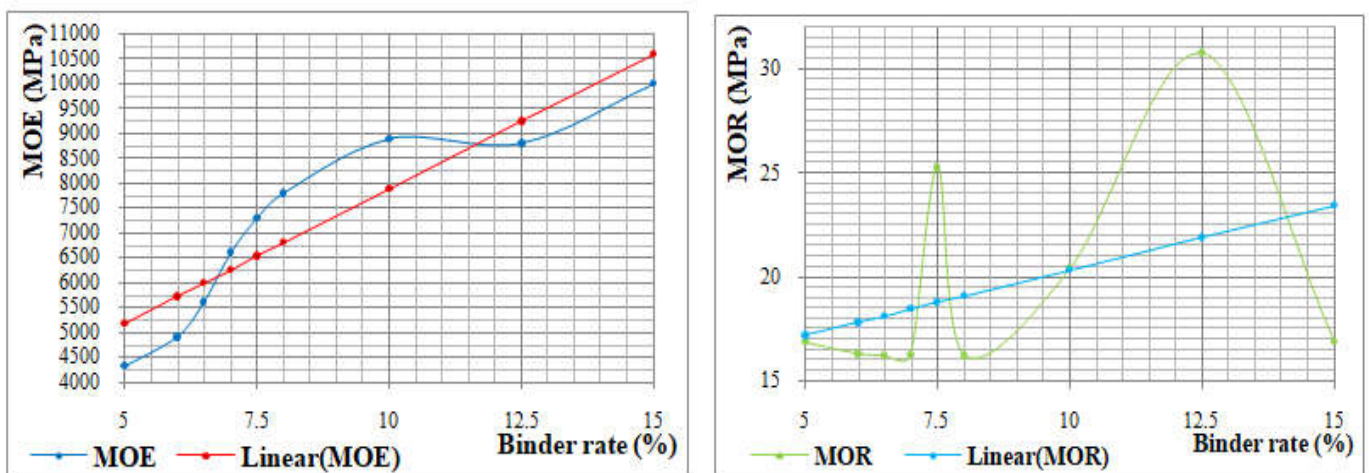

Figure 7. Variation of the modulus of, elasticity (MOE) and rupture (MOR) according to the binder rate

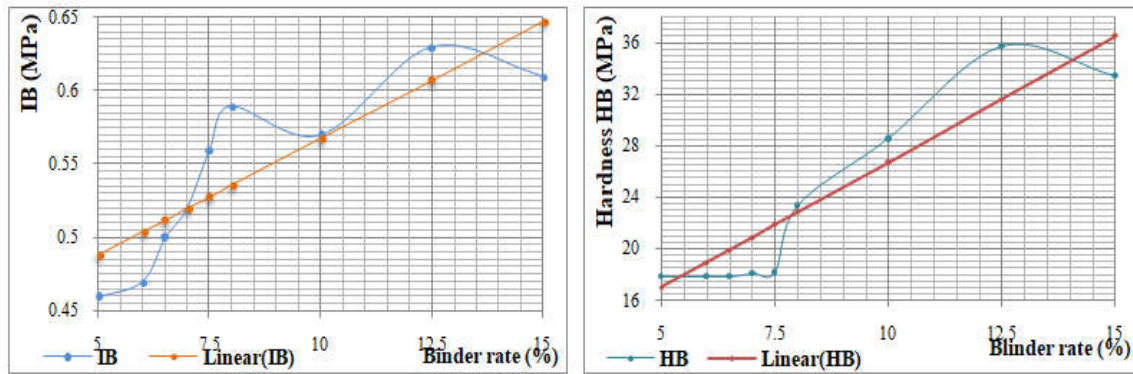

Figure 8. Variation of the internal bound (IB) and hardness (HB) according to the binder rate

Table 5. Thermal conductivity of teak sawdust particleboards

Binder rate (%)	5	6	6,5	7	7,5	8	10	12,5	15
λ (W/m.°C)	0.077	0.0774	0.0778	0.0814	0.085	0.0786	0.0708	0.0767	0.0722

λ : thermal conductivity.

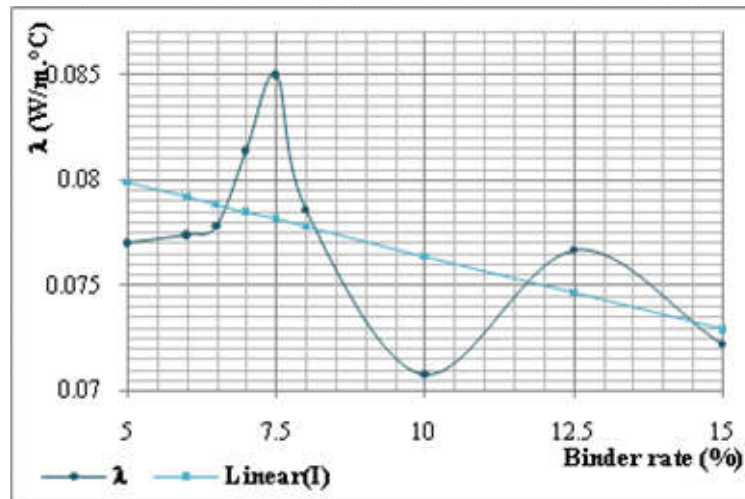

Figure 9. Variation of the thermal conductivity coefficient according to the binder rate

$$MOE = \frac{(F_2 - F_1) l^3}{4 b e^3 (y_2 - y_1)} \tag{2}$$

With: l: length between supports; b: width of the sample;

e: thickness of the sample; F: tensile strength;
 $F_1 = 10\% F$; y_1 : the arrow corresponding to F_1
 $F_2 = 40\% F$; y_2 : the arrow corresponding to F_2 .

The modulus of rupture is given by the following equation:

$$MOR = \frac{3 F l}{2 b e^2} \tag{3}$$

With: l: length between supports; b: width of the specimen; e: thickness of the sample; F: tensile strength;

$$E = \frac{F.l}{b.e.\Delta l} \tag{4}$$

With: l: original length; b: width of the specimen;
 e: thickness of the sample; F: yield strength;
 Δl : different between length variation.

The tensile modulus of rupture is given by the following equation:

$$MOT = \frac{F_m}{b e} \tag{5}$$

With: b: width of the specimen; e: thickness of the sample; F_m : maximal strength;

The Internal Bond (IB) of each particleboard is made according to the NF-EN 319 with ten specimens which dimensions are 50 mm x 50 mm subjected to perpendicular tensile on the faces. The internal bound is calculated by the below equation.

$$IB = \frac{F_m}{S} \tag{6}$$

According to the US standard (ANSI A208.1., 2009), the reference values for the mechanical and the physical properties of particleboard is presented in Table 2. They serve as a reference for the validation of our experimental results.

Physical properties determination: The physical characteristics which are the density, the thickness swelling and water absorption, are determined as follows:

The density is determined according to EN323 on ten samples of 50 mm x 50 mm for each prepared panel. It is calculated by the following equation:

$$\rho = \frac{M}{V} \quad (7)$$

$$V = e \times l^2 \quad (8)$$

With: M: mass of the sample; V: volume of the sample;

e: thickness of the sample; l: side of the sample;

ρ : density of the panel.

The swelling test consists of immersing the samples of each panel whose mass and thickness are determined before in water. Then raises the mass and the thickness of the samples after 2 hours and then after 24 hours. This determines the rate of water absorption (TA) of panels and its thickness swell in grate (TS) according to (EN 317, 1993).

$$TA (\%) = \frac{m_0 - m_i}{m_0} \times 100 \quad (9)$$

With m_0 : samples mass before immersion (g)

m_i : samples mass after immersion (g)

TA: water absorption rate (%)

$$TS (\%) = \frac{e_0 - e_i}{e_0} \times 100 \quad (10)$$

With e_0 : samples thickness before immersion (mm)

e_i : samples thickness after immersion (mm)

TS: Thickness swelling rate (%)

Thermal property determination

The thermal property considered herein is the thermal conductivity coefficient. It is measured by the method of hot semi – infinite plane whose block diagram is shown in Figure 2.4.

$$\lambda = \frac{\phi \cdot e}{T_1 - T_2}$$

With ϕ : heat flux ($W \cdot m^{-2}$)

λ : thermal conductivity ($W \cdot m^{-1} \cdot K^{-1}$)

e: thickness of the solid (m)

T_1, T_2 : wall temperatures (K or °C)

RESULTS AND DISCUSSION

Physical properties: The density, thickness swelling and water absorption for the different particleboards are summarized in table 3. The density of the panels ranging from 615.95 kg/m^3 and 741.9 kg/m^3 classifies the Teak particleboards with locust bean husk powder in medium density panels by (ANSI A 208.1-2009). The curves of Figures 4 and 5 represent the variation of the physical characteristics according to the binder content, the tannic powder of African locust bean husk. It is seen that:

- The density describes a sinusoidal with a minimum which is 615.95 kg/m^3 at 12.5% and a maximum of 741.9 kg/m^3 at 5%. The linear trend model of the density shows that it increases little with the rate of the binder;
- The thickness swelling rate varies from 12.22% at 7.5% binder to 59.44% by 6.5% in 2 hours and 42.37% by 7.5% to 66.25% binder in 7% and 6.5%. The parallelism of the both linear trend models proves that the swelling speed is constant;
- The water absorption rate ranges from 53.85% at 15% to 150% at 5% of binder in 2 hours and 92.86% at 15% to 188.9% in 6.5% of binder. The same observation is made for the water absorption speed, but the increase of the water absorption rate is between 6.5% and 7% of binder.

The results are slightly above the requirements of existing standards and show signs that teak with tannin powder of African locust bean pod cannot be used in outdoor environments.

Mechanical properties: To determine the mechanical properties of the particleboards, four different tests were made: bending, tensile, internal bound and Brinell hardness. The results of those tests are summarized in the table 4. The pressing time of 15 minutes at the temperature of 160 °C and the pressure of 11 bars giving the highest modulus of elasticity at 15% and rupture at 12.5% of binder, is in accordance with the conventional pressing time of 5 to 15 min at a pressure of 10 to 30 bar (Godbille F. D 2002). These results confirm those of Villeneuve (2006) and that of Chow (1978). Figures 6 to 8 represent the variation of the mechanical characteristics according to the binder rate, the tannic powder of African locust bean husk. We can observe that: the Young's modulus (E) increases with the binding rate as showed by the linear trend model. Its sinusoidal form reflects the wood murphy. They confirm the results of (Kadja, 2012) on kenaf particleboard with bone glue beads,

- The variation of the tensile modulus of and the modulus of rupture (MOT) is sinusoidal. The panels of 10% have the less modulus,
- The bending modulus of elasticity increased quickly, showing that the particleboards of teak sawdust become flexible with increasing the binder content. This is explained by the fact that sawdust teak is stiffer than the African locust bean pod,
- The variation of the bending modulus of rupture has the same shape as the curve of the tensile modulus of elasticity but it decreases slowly at 5 to 7% of the binder. The amplitude increases with the proportion of the binder. It follows the arrow decreases inversely relative to the binder content,
- The internal bound increases with the binder rate. The best hardness is observed at 12.5%.
- The Brinell hardness shows the same variation as the internal bound.

The mechanical properties are respectful to the American National Standardization Institute (ANSI A208.1., 2009).

Thermal properties: The thermal conductivity coefficient is the thermal property evaluated in the present study. The result is shown in the table 5.

The change in the binding rate does not affect so much the thermal conductivity coefficient. The curve has a maximum of 0.085 W / m.°C at 7.5% of binder and a minimum 0.0708 W / m.°C at 10% of binder. The Variation of the thermal conductivity coefficient according to the binder rate is represented in Figure 9.

Conclusion

This work shows that the non-conventional binder that represents the tannin powder of African locust bean pod can be used to develop the sawdust particleboard specially those of teak. The panels obtained have mechanical properties that meet international standards as with conventional binders that caused environmental problems. Very good internal bound values that meet ANSI A208.1-2009 have been obtained. The Teak sawdust particleboard with the pod husk powder (*parkia biglobosa*) can replace non-green panels. Thickness swelling rate and water absorption rate indicate that the panels developed may be used in dry conditions. The low thermal conductivity coefficient shows that these panels can be used in interior plating for thermal insulation.

Acknowledgement

The authors thank the Ministry of Agriculture Livestock and Fisheries for the financial support of this project by WAAPP – TOGO (PPAAO – TOGO). The coordinator receives our compliments. They are also grateful to the officials of LERMAB André MERLIN in occurrences and the director of ENSTIB of the University of Lorraine to host in their laboratories and the responsible of FEMTO – ST namely: Emmanuel FOLTETE, of the University of Franche Comté.

REFERENCES

- ANSI A208.1, (2009). Medium density fibreboard, Gaithersburg : Published by National Particleboard Association, 11p
- Beyer R., A., (1997). Method of scavenging formaldehyde using a low mole ratio melamine – urea – formaldehyde resin United State Patent, Vol. 5684118.
- Chudnoff Martin Tropical timbers of the world [Revue]. - Washington, D.C: USDA Forest Service Agriculture Handbook , 1984. - 464 p. : Vol. 607.
- Drovou S. [et al.] Flavonoid tannins linked to long carbohydrate chains – MALDI-TOF analysis of the tannin extract of the African locust bean shells [Revue]// Industrial Crops and Products. - Lomé (Togo) : [s.n.], 2015. - 25–32 : Vol. 67.
- DSCN TOGO. Inventaire des matériaux composites au Togo [Rapport]. - Lomé : Direction de la Statistique et de la Comptabilité Nationale, 2015.
- EPF cost development of particle board industry in Europe [Revue]. - [s.l.] : EU research framework programs, 2006.
- Huang et Ferraro Phenolic-compounds in food and cancer prevention [Revue]. - [s.l.]: ACS Symposium, 1992. - 507.
- IARC monographs on the evaluation of carcinogenic risks to humans [Ouvrage]. - Lyon France : Wood dust and formaldehyde, 1995. - Vol. 62.
- Kahrl Fredrich et Horst Weyerhaeuser and Su Yufang Navigating the Border: An Analysis of the China-Myanmar Timber Trade. [Revue]. - China-Myanmar: China and forest trade in the Asia-Pacific region: Implications for forests and livelihoods Forest Trends, 2004.
- Keiding H. teak, *Tectona grandis*, Seed leaflet [Revue]. - Humlebaek, Denmark: Danida Forest Seed Centre, 1985. - 21 p : Vol. 4.
- Lavisci P. [et al.] determination test for structural wood adhesives used in thick joints [Revue]// European Journal of Wood products . - [s.l.] : European Journal of Wood products, 2001. - 1-2: 153-154 doi: 10.1007/s001070050487. : Vol. 59.
- Nenonene Yao Amen Elaboration et caractérisation mécanique de panneaux de particules de tige de kénaf et de bioadhésifs à base de colle d'os, de tannin ou de mucilage [Revue]// Thèse de doctorat de l'Université de Toulouse. - 2009. - p. France.
- Orica Limited Urea formaldehyde resin production process [Ouvrage]. - 1999.
- Pandey D. and Brown C. (2001). Teak: a global overview [Revue]. - Unasylva : Teak, - 201 : Vol. 51- 2000/2 .
- Pandey D. et Brown C. Le teck dans le monde. Archives de documents de la FAO. Département des forêts [Revue]. - Rome, Italie : FAO, 1983.
- White K., J., Teak, some aspects of research and development [Revue]. - FAO, Bangkok: RAPA Publication, 1991. - FAO Regional Office for Asia and the Pacific., 69 p : Vol. 1991/17.
- Yemele Développement de panneaux de particules à base d'écorce d'épinette noire et de peuplier faux tremble [Revue]. - LAVAL : PhD University LAVAL, 2008.
- ANSI A 208 1, 2009. Medium density fibreboard, Published by National Particleboard Association, Gaithersburg, MD, 11P.
- Berhaut J. 1975. Flore Illustrée du Sénégal. Dakar, Min. du Dév. Rural. Dir. Des Eaux et Forêts.
- Beyer R. A., 1997. *Method of scavenging formaldehyde using a low mole ratio melamine – urea – formaldehyde resin.* United State Patent 5684118.
- CHOW P., 1978. Phenol adhesive bonded medium – density fibreboard from *Quercus rubra* L. bark and sawdust. Wood and fibre Science, 11(2): 92 – 98.
- Chudnoff, Martin. 1984. Tropical timbers of the world. USDA Forest Service Agriculture Handbook no. 607. Washington, D.C. 464 p.
- DCN TOGO, 2010. Direction de la comptabilité Nationale. Togo
- De Camino, R. V; MM. Alfaro and L. F. M. Sage. 2002. Teak (*Tectona grandis*) in Central America. Forest plantations working paper 19, Forest Resources Development Service, Forest Resources, Division, FAO, Rome (28 p).
- EN 312 – 2, 2004. Panneaux de particules. Type P2, Stand P3 – MH, P4 CTBH.
- EN 310 NF B51 – 124, 1993. Panneaux à base de bois – Détermination du module d'élasticité et de la résistance à la flexion AFNOR.
- EN 322 B51 – 121, 2003. Panneaux à bois détermination de l'humidité.
- EN 317, 1993. Particleboards and fiberboards, Determination of Thickness Swelling after Immersion European Standardization Committee, Brussels.
- EPF, 2006. EU research framework programs; cost development of particle board industry in Europe
- Fafioye O.O., Adebisi, A.A., Fagade S.O, 2004. Toxicity of *Parkia biglobosa* and *Raphia vinifera* extracts on *Clarias gariepinus juveniles*. *African Journal of Biotechnology*3:627-630

- FAO, 2001. Global Forest Resources Assessment 2000, FAO, Forestry Department, Main report 140, Rome.
- Godbille F. D., 2002. A simulation model for the hot pressing of particleboard. *Thèse de Doctorat, University of Brunswick. 177p.*
- Huang M. T. et Ferraro T., 1992. Phenolic – Compounds in food and cancer prevention, ACS Symposium, Ser. 507.
- Horne, J.E.M., 1966. Teak in Nigeria. Nigerian Information Bulletin (New Series) No. 16.
- IARC., 1995. monographs on the evaluation of carcinogenic risks to humans. Vol 62 : Wood dust and formaldehyde. Lyon France.
- Kadambi, K., 1972. Silviculture and management of teak. Bulletin No. 24, School of Forestry, Stephen F. Austin State University, Texas, USA.
- KADJA K., 2012. Elaboration et Caractérisation mécanique et thermique des panneaux de kénaf (*Hibiscus cannabinus L.*) et de cotonnier (*Gossypiumhirsutum L.*). *Thèse de Doctorat, Université de Lomé.*
- Kahr, Fredrich; Horst Weyerhaeuser and Su Yufang, 2004. Navigating the Border: An Analysis of the China-Myanmar Timber Trade. In: China and forest trade in the Asia-Pacific region: Implications for forests and livelihoods. Forest Trends. (<http://www.forest-trends.org>)
- Keiding, H. 1985. Seed leaflet no.4, teak, *Tectona grandis*. Danida Forest Seed Centre, Humlebaek, Denmark. 21 p.
- Lavisci P., Berti S., Pizzo B., Triboulotand P., Zanuttini R., 2001. A determination test for structural wood adhesives used in thick joints. *European Journal of Wood products*. Volume 59, Numbers 1 – 2: 153 – 154.
- Mapongm et sem P M, Nkongmeneck B A et Denedoumba D. 2004. Germination et croissance initiale d'une Mimosaceae alimentaire locale : *Parkiabiglobosa* (Jacq.) Benth. *Procédés Biologiques et Alimentaires*. (2) Revue N°2. <http://www.fao.org/ag/aga/agap/frg/afris/fr/Data/137.HTM>
- Ndir B, Lognay G, Wathelet B, 2000. Composition chimique du nétéu, condiment alimentaire produit par fermentaire des graines du caroubier africain *Parkiabiglobosa* (Jacq.) Benth. *Biotechnol. Agron. Soc. Environ* 4 (2): 101 -105.
- Nenonene A. Y., 2009. Elaboration et caractérisation des panneaux de particules des tiges de kénaf à base des bioadhésif, de la colle d'os, des tannins ou de mucilage. *Thèse INP de Toulouse.*
- Yemele M.C.N., 2008. Développement de panneaux de particules à base d'écorce d'épinette noire et de peuplier faux tremble. PhD University LAVAL.
- ORICA Limited, 1999. Urea formaldehyde resin production process.
- Pandey, D., Brown, C., 2001. Teak: a global overview in: Teak No. 201, Unasylva Vol. 51- 2000/2
- Streets, R. J. 1962. Exotic trees of the British Commonwealth. Clarendon Press, Oxford,
- Swe Swe Aye, Daphne Khin. 2003. GAIN Report BM3015, Burma, Solid Wood Products Annual 2003, Foreign Agricultural Service, Global Agriculture Information Network, 5/29/2003, USDA, Rangoon, Burma
- Tchiégang-Megueni C, Mapongmetsem PM, Akagou Zedong HC, and Kapseu C., 2001. An ethno botanical study of indigenous fruit trees in northern Cameroon. *Forests, Trees and Livelihoods*. 11: 149-158.
- Villeneuve E., 2005. Utilisation de l'écorce de peuplier faux – tremble pour la fabrication de panneaux de particules. Maîtrise en science du bois. *Faculté de foresterie Université LAVAL.*
- White, K. J., 1991. Teak, some aspects of research and development. RAPA Publication 1991/17. FAO Regional Office for Asia and the Pacific, FAO, Bangkok. 69 p.
