



ISSN: 0975-833X

Available online at <http://www.journalcra.com>

INTERNATIONAL JOURNAL  
OF CURRENT RESEARCH

*International Journal of Current Research*  
Vol. 13, Issue, 11, pp.19713-19715, November, 2021

DOI: <https://doi.org/10.24941/ijcr.42610.11.2021>

## RESEARCH ARTICLE

### A PROPOSED NEW TOPOLOGY FACTS CONTROLLER FOR REACTIVE POWER CONTROL IN NON LINEAR LOADS

Namburi Nireekshana<sup>1,\*</sup>, Akhila Reddy, B.<sup>2</sup> Keerthi Reddy, G.<sup>3</sup> and Keyooralaya, A.<sup>4</sup>

<sup>1</sup>Assistant Professor, EEE Department, Methodist College Engineering and Technology

<sup>2,3,4</sup>EEE Department, Methodist College Engineering and Technology

#### ARTICLE INFO

##### Article History:

Received 15<sup>th</sup> August, 2021  
Received in revised form  
29<sup>th</sup> September, 2021  
Accepted 18<sup>th</sup> October, 2021  
Published online 30<sup>th</sup> November, 2021

##### Keywords

Reactive power,  
STATCOM,  
MATLAB Simulink

##### \*Corresponding author:

Namburi Nireekshana

#### ABSTRACT

Reactive power problems usually occur at the interconnection points of different systems or now in the deregulated market between different owners of transmission or distribution networks, reactive power generators and consumers. As reactive power is a local product its value to system security and voltage control very much depends on the location in the system. STATCOM is a device that regulates the voltage level or the reactive power in the system. It is used to maintain voltage stability, enlargement of critical clearing time. In this paper Simulation has been done with one example

Copyright © 2021. Namburi Nireekshana et al. This is an open access article distributed under the Creative Commons Attribution License, which permits unrestricted use, distribution, and reproduction in any medium, provided the original work is properly cited.

Citation: Namburi Nireekshana, Akhila Reddy, B. Keerthi Reddy, G. and Keyooralaya, A. "A proposed new topology facts controller for reactive power control in non linear loads", 2021. *International Journal of Current Research*, 13, (11), 19713-19715.

## INTRODUCTION

Reactive power gives the important function of regulating voltage. If voltage on the system is not high enough, active power cannot be supplied. Reactive power is used to provide the voltage levels necessary for active power to do work which is useful. Reactive power is required to move active power through the transmission and distribution system to the customer. Reactive power is needed to maintain the voltage to deliver active power (watts) through transmission lines. If some active power is transferred to the load, there must be the presence of the reactive power in a transmission line assuming there's no power factor correction instrument connected to it. Reactive power is the component of power which is settled by the inductor in the form of magnetic field in the transmission line. It is unwanted, as it reduces effective power transfer capability of the transmission system, but is present due to the inductive elements present in the power system. If you apply power factor corrections at the load end, suppose before an induction motor, there will not be any reactive power consumptions by the total load.

(Although, motor draws the reactive power which is compensated by Capacitor bank, resultant effect on the generator is zero). Real power achieves useful work while reactive power holds up the voltage that must be controlled for system reliability. Reactive power has an intense effect on the security of power systems because it affects voltages throughout the system Reactive power is important because of

**Voltage control:** Power system equipment is designed in a way to operate within  $\pm 5\%$  of the nominal voltages. Fluctuations in voltage levels lead to break down of the various appliances. High voltage damages the insulation of windings whereas low voltage causes poor performance of the various equipment like low illumination of blubs, overheating of induction motors, etc. If the power demand is higher than that supplied by transmitting lines, current drawn from supply lines goes to a higher level, which causes the voltage to fall extremely at the receiving end side. If this low voltage is decreased further, it leads to the tripping of generator units, overheating of motors and other equipment failures. To overcome this, reactive power should be supplied to the load by putting reactive inductors or reactors in transmission lines.

The capacity of these reactors depends on the amount of apparent power to be supplied. If the power demand is less than reactive power supplied, the load voltage rises to a higher level which leads to automatic tripping of transmission equipment, low power factor, insulation failures of the cables and windings of various mechanical devices. To overcome this, additional reactive power available on the system must be compensated. Various compensation equipment is synchronous condensers, shunt capacitors, series capacitors, and other PV systems. These devices inject the capacitive reactive power to compensate inductive reactive power in the system.

**Proper working of various devices/machines:** Transformers, motors, generators and other electrical devices require reactive power to produce magnetic flux. This is because the generation of magnetic flux is necessary for these devices to do useful work. In the above figure reactive power, indicated by red color, helps to create a magnetic field in the motor but it leads to a decrease in the power factor. This is why a capacitor is placed to compensate for the inductive reactive power by supplying capacitive reactive power.

**Sources and Sinks of Reactive Power:** There are two types of reactive power sources namely dynamic and static reactive power sources.

**Dynamic Reactive Power Sources:** These include transmission equipment and devices, which are capable to respond to the reactive power changes quickly by injecting or providing a sufficient amount of reactive power into the electrical system. These are of more cost and some of these devices are

- Synchronous generators:
- Synchronous condensers:
- Solid state devices: power electronic converters and FACTS by SVC devices.

**Static Reactive Power Sources:** These are low-cost devices and response to reactive power variation is somewhat less than the dynamic power devices. Some of the static resources are given below.

- Capacitive and inductive compensators:
- Underground cables and overhead lines:.
- PV systems: These are used for active power injection as well as harmonic and reactive power compensation in the grid systems by photovoltaic power.

## Proposed Topology

### STATCOM

- STATCOM is a static synchronous compensator which is also known as STATCON a static synchronous condenser.
- STATCOM is used for alternating current electricity transmission networks as it is a regulating device
- It is one of the important device for FACTS that is Flexible AC Transmission System. It provide active AC power
- The STATCOM is a voltage converter mostly a DC capacitor with an energy storage unit. It is a DC-AC converter

- As STATCOM is a voltage sourced converter, it mostly uses three phase converter as its core. The voltage output of the system is connected through transformer or reactor. absorb or produce reactive power by regulating AC voltage amplitude. STATCOM compensate current for impact load. It also compensate harmonic current

**Working:** It is a voltage source converter-based device. The STATCOM has very little active power capability because of the voltage created from DC capacitors. But the active power capability can increase by connecting a suitable energy source with the DC capacitor. The amplitude of the voltage source will decide the reactive power at the terminals of the STATCOM. If the terminal voltage of VSC is higher than the AC voltage at the point of connection, the STATCOM generates a reactive current. And if the terminal voltage of VSC is lower than the AC voltage at the point of connection, the STATCOM absorbs the reactive power. The response time of the STATCOM is shorter than the Static VAR Compensation (SVC). Due to fast switching using IGBTs of voltage source converter. The STATCOM provides better reactive power support at low AC voltage than an SVC. Since the reactive power from a STATCOM decreases linearly with the AC voltage.

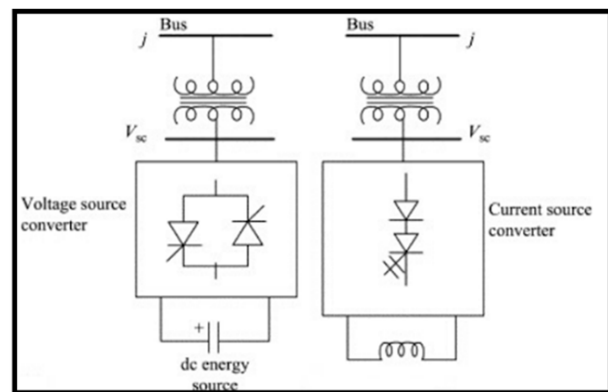

Figure 1. Diagram Of Statcom

**Principle of Operation:** A STATCOM is a controlled reactive-power source. It provides the desired reactive-power generation and absorption entirely by means of electronic processing of the voltage and current waveforms in a voltage-source converter (VSC)

- STATCOM is seen as an adjustable voltage source behind a reactance i.e capacitor banks and shunt reactors are not needed for reactive-power generation and absorption, thereby giving a STATCOM a compact design, or small footprint, as well as low noise and low magnetic impact.
- If the output voltage equals the ac system voltage, the reactive-power exchange becomes zero, in which case the STATCOM is said to be in a floating state.
- Adjusting the phase shift between the converter-output voltage and the ac system voltage can similarly control real-power exchange between the converter and the ac system. In other words, the converter can supply real power to the ac system from its dc energy storage if the converter-output voltage is made to lead the ac-system voltage.

- On the other hand, it can absorb real power from the ac system for the dc system if its voltage lags behind the ac-system voltage.

**Advantages of STATCOM**

- It occupies a small footprint, for it replaces passive banks of circuit elements by compact electronic converters.
- It offers modular, factory-built equipment, thereby reducing site work and commissioning time; and
- It uses encapsulated electronic converters, thereby minimizing its environmental impact.
- Fast time response.
- Active power control is possible.
- Components that are used in the STATCOM are smaller than SVC.
- Characteristics are superior.
- The output voltage is nearly equal to the input DC voltage.
- Better transient response.
- It reduces harmonic to minimum level.
- It reduces equipment volume and foot-print.

**Applications of STATCOM**

- This device used in long-distance transmission lines and power substations. For voltage stability, it used in industries where a large amount of reactive load connected.
- Reactive power compensation
- Better voltage control
- Maintain balance in each phase of the transmission line
- Reduce harmonics
- Power factor correction
- Increase the power transfer capacity of the transmission line
- Reduce temporary over-voltage condition in the transmission line
- Improve transient stability

**RESULTS AND SIMULATION**

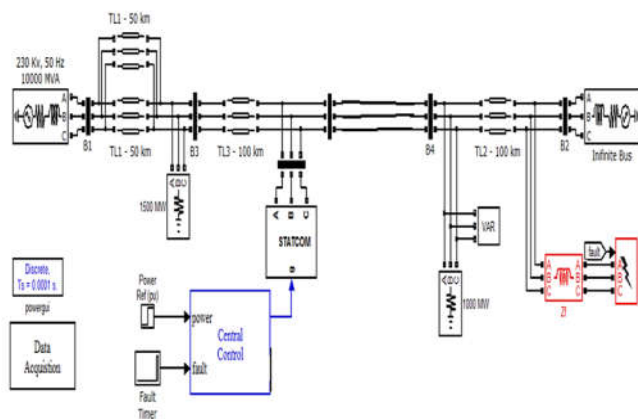

Figure 2. Simulation diagram of STATCOM

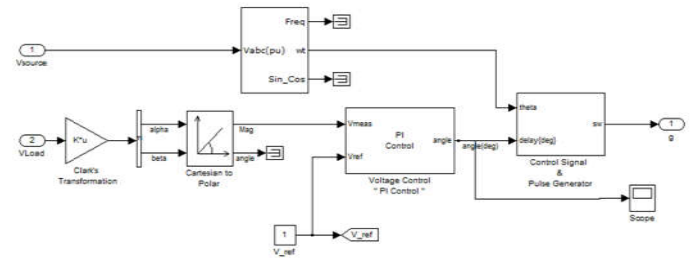

Figure 3.2. Representation of control circuit

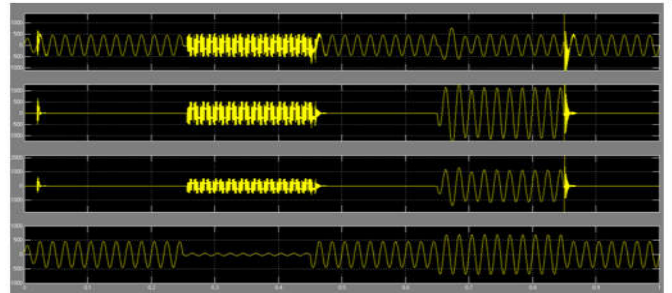

Figure 3. Simulation results

**CONCLUSION**

To improve power quality in the power transmission system, there are some effective methods. In this project, the voltage sag and swell mitigation, using a new FACTS device called STATCOM is presented.

**REFERENCES**

- A Peer Survey on Load Frequency Control in Isolated Power System with Novel Topologies Namburi Nireekshana R. Ramachandran International Journal of Engineering and Advanced Technology, ISSN: 2249-8958 (Online).
- A novel-implementation-fuzzy-pi-based-distributed-power-flow-controller-power-quality improvement and mitigation namburi nireekshana, INTERNATIONAL JOURNAL OF CURRENT RESEARCH, Vol 13 Issue:10
- Nireekshana, Namburi. "Control of a Bidirectional Converter to Interface Electrochemical double layer capacitors with Renewable Energy Sources."
- Nireekshana, Namburi. "Reactive Power Compensation in High Power Applications by Bidirectional cascaded H-Bridge Based Statcom."
- Prasad, CS Pavan, and N. Nireekshan. "A Higher Voltage Multilevel Inverter with Reduced Switches for Industrial Drive." International Journal of Science, Engineering and Technology Research (IJSETR) 5.1 (2016).
- Rajinikanth, Bhumaiah Jula, and N. Nireekshan. "Improving the Voltage Profile at Load End using DVR." (2018).
- Jatoth, Ramesh, and N. Nireekshana. "Improvement of Power Quality in Grid Connected Non Conventional Energy Sources at Distribution Loads." (2018).

\*\*\*\*\*